

# SIMATEK BUCKET ELEVATOR MEASURE SHEET, BUCKETS

5 buckets pr. meter of chain

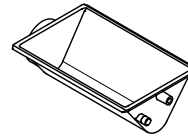

Type 33:  
Injection moulded  
3,2l

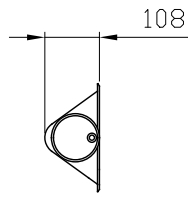
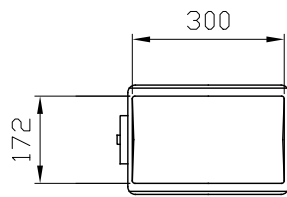
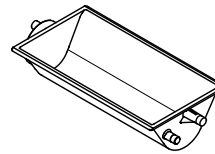
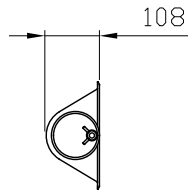
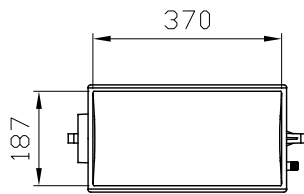

Type 44:  
Injection moulded  
4,4l  
Stainless Steel  
4,7l

3,3 buckets pr. meter of chain

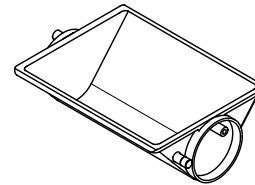
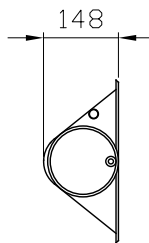
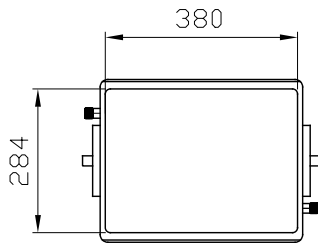

Type 110:  
Injection moulded  
9,4l  
Stainless steel  
10l

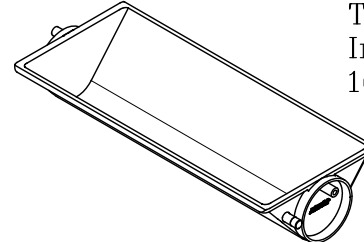
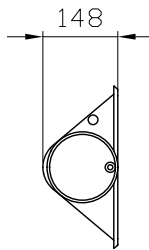
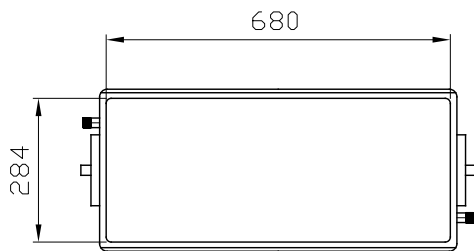

Type 160:  
Injection moulded  
16,1l

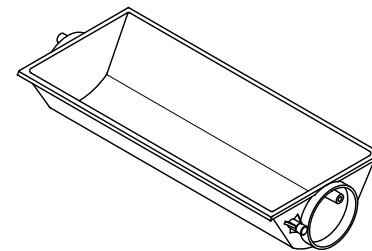
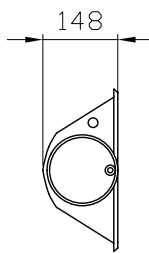
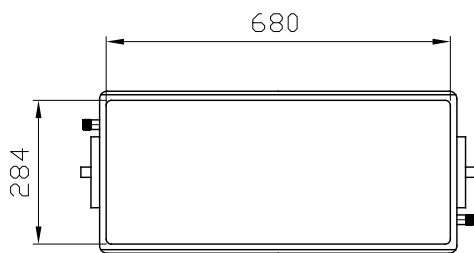

Type 200:  
Inj. moulded  
18,5l  
Stainless steel  
20,5l  
Thermoformed  
19l

2,5 buckets pr. meter of chain

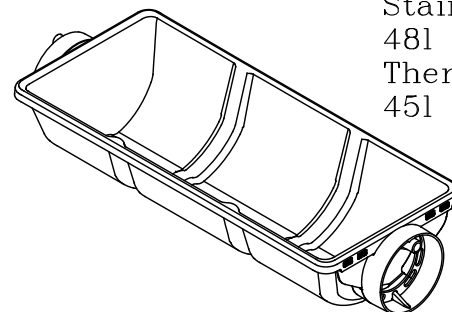
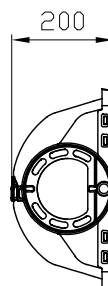
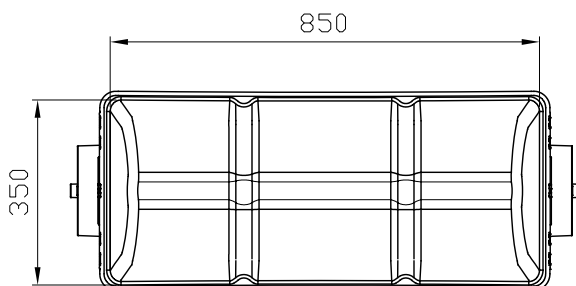

Type 400:  
Stainless steel  
48l  
Thermoformed  
45l